

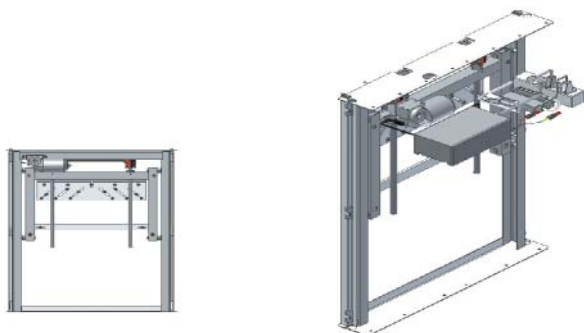

VertiElectric - Electrical height adjustable frame for wall units, ideal for sheltered housing and in private homes

- This electric wall unit frame enables the user to reach items in a wall unit that otherwise would be impossible to reach
- The system raises and lowers wall units 300 mm vertically, simply by pushing a control switch, normally located in fascia below the worktop, switch is included
- The framework remains completely hidden throughout the movement
- Only 50 mm of extra projection is added to the wall units, so that there is still worktop space in front of the units at the low position
- A safety stop plate should be fitted below the units to prevent the risk of trapping anything on the worktop below. Lights can be fitted in the safety stop plate to improve visibility.



VertiElectric height adjustable frame for wall units

- Frame width 600 mm for wall unit widths 600-1200 mm
- Frame height 700-900 mm for wall unit heights 700-900 mm
- Installation notes:
 Allow a space of 3-5 mm either side of the units for free movement
 To line up adjacent fixed wall units space them off the wall by 50 mm
 Wall units should have a solid top and base.

Smaller doors of 300/400 mm may be easier to open at worktop height without having to step back.

Consider the location of the control switch - if there is space below the worktop the fascia is normally best - if there are units below the VertiElectric, a remote control may be more practical

Fixings are not included - order separately to suit substrate

- Max. load on frames 80 kg/ms.
- White painted steel

For wall unit width	Cat. No.
600-1200 mm	506.17.730

Order qty: 1 pc

VertiElectric bottom rail

- Order separately, for use with frame shown above
- White painted steel

Length	Cat. No.
600 mm	506.17.741
700 mm	506.17.742
800 mm	506.17.743
900 mm	506.17.744
1000 mm	506.17.745
1100 mm	506.17.746
1200 mm	506.17.747

Order qty: 1 pc

Remote control

- For use with VertiElectric and Flexi system
- 2x AAA batteries required (not included)



	Cat. No.
Remote control	506.17.999

Order qty: 1 pc

Safety stop plate

- For use with VertiElectric height adjustable frame for wall units
- To prevent the risk of trapping



For wall unit width	Cat. No.
600 mm	506.17.051
700 mm	506.17.052
800 mm	506.17.053
900 mm	506.17.054
1000 mm	506.17.055
1100 mm	506.17.056
1200 mm	506.17.057

Order qty: 1 pc

Smartbox

- Smartbox is an intelligent system to avoid trapping
- One Smartbox is needed per frame for two or more adjacent FlexiElectric worktop frames and a VertiElectric wall unit frame above a FlexiElectric frame
- Movement up or down is stopped on every frame when any safetystop is activated



	Cat. No.
Smartbox	506.17.995

Order qty: 1 pc

TCH-FF 2010, HUK. Dimensional data not binding. We reserve the right to alter specifications without notice.