

## EXTRACTOR FAN SETS

### Professional Showerlite

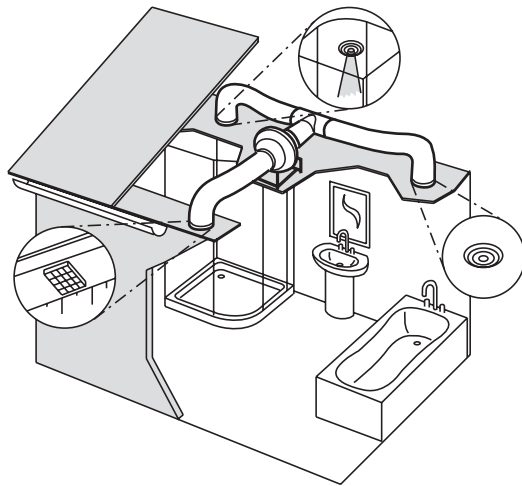

- > 12V extractor fan incorporating an integral 12V 35W halogen lamp
- > Extracts up to 180m<sup>3</sup>/hr, 50 litres per second
- > Complies with EN 60335-2-80
- > Meets 2006 building regulations Doc F1
- > Set includes:
  - 1x 12V/35W Halogen lamp, polished chrome fascia
  - 1x white internal vent
  - 1x Transformer input 230V AC Output 12V AC Max.
  - 1x Extractor fan
  - 1x Fixing set
  - 1x External vent
  - 1x Fitting instructions
- > Order qty: 1 set



Finish  
Polished chrome/white

Cat. No.  
828.01.730

### Centrifugal in-line fan set

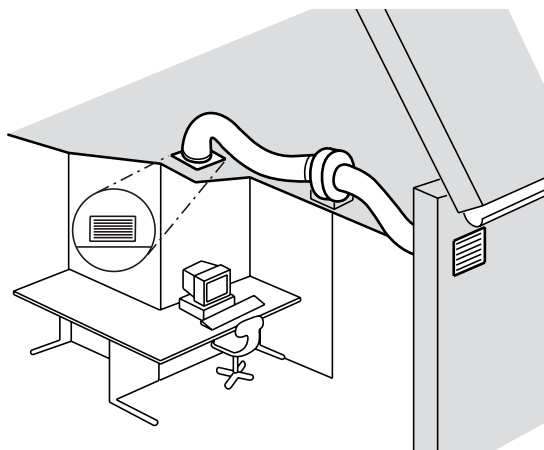

- > Available in standard or timer version
- > Standard version: switches on and off when light switch is switched on and off
- > Timer version: switches on when light switch is switched on. Once switched off will automatically run between 20 secs - max. 15 mins
- > Extracts up to 110m<sup>3</sup>/hr, 31 litres per second
- > Complies with EN 60335-2-80
- > Meets 2006 building regulations Doc F1
- > Set includes:
  - 1x Internal vent, white fascia
  - 1x Internal vent, polished chrome fascia
  - 1x Transformer input 230V AC Output 12V AC Max.
  - 1x Extractor fan
  - 1x Fixing set
  - 1x External vent
  - 1x Fitting instructions
- > Order qty: 1 set



Finish  
Polished chrome/white

Standard version  
828.01.740

Timer version  
828.01.741