

Support for worktop

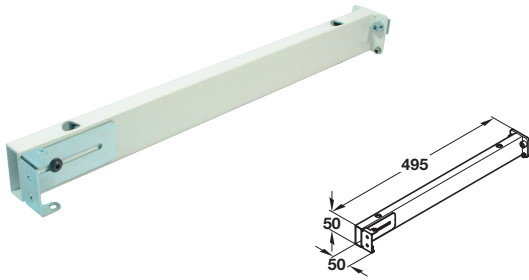

- > Supports worktop depth 600-620 mm
- > Dims (HxWxD): 50 x 495 x 50 mm
- > Painted steel
- > Order qty: 1 pc

Finish	Cat. No.
White	506.16.740

Winding handle

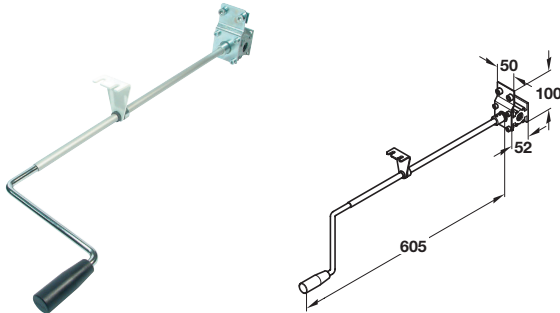

- > For manual adjustment of worktop system
- > Includes transmission
- > Aluminium
- > Order qty: 1 pc

Finish	Cat. No.
Aluminium	506.16.950

Motor and control box



- > For electric adjustment of worktop system
- > Motor, includes 3000 mm cable
- > Control box, for 1 or 2 motors, includes control switch and cables
- > Order qty: 1 pc



Control switch - For adjustment of worktop and cupboard height. Included with control box. Buttons are easy to read and operate



Full details for the control box is shown on page 285

Item	Cat. No.
Motor	506.16.360
Control box for 1 motor	506.16.374
Control box for 2 motor	506.16.371

Flexible safety strip



Safety strips ensure that worktops don't just stop, but reverse their movement immediately when activated.

- > For worktop system and adjustable table frame
- > Automatic safety stop to ensure that nothing gets crushed beneath worktop fascia
- > Allow sufficient for fascia front and returns in one piece
- > Safety strip length can be cut to exact size required
- > Note: This safety strip must be used with all electric worktop systems
- > Order qty: 1 pc

Strip length	Cable length	Cat. No.
1600 mm ± 30mm	1500 mm	506.17.931
2400 mm ± 30 mm	1500 mm	506.17.932
3200 mm ± 30 mm	1500 mm	506.17.933
4200 mm ± 30 mm	1500 mm	506.17.934