

# VAUTH SAGEL CORNERSTONE MAXX STORAGE UNIT

1

Easy to assemble pull out shelving unit with shelves that operate independantly. Once open shelves do not block adjoining cabinets.

Kitchen Fittings and Accessories: Storage



Cornerstone Maxx pull out shelving unit with Planero lava grey shelves, right hand

- > EasyFit: tool-free assembly of shelf elements on the support arms
- > PAM: Power assisted movement in pull-out direction
- > Simple height adjustment, even when installed
- > The bases can be moved in and out independantly and do not obstruct the adjacent cabinet
- > Floating design due to hidden fastening
- > Large area shelves
- > Each shelf has a 25 kg load capacity

## Cornerstone Maxx pull out shelving unit

Max. 25 kg per shelf

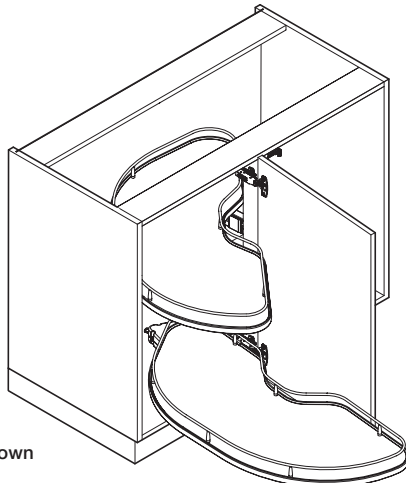

Left hand shown

- > Suitable for 800, 900 or 1000 corner base cabinets
- > Built-in depth: min. 490 mm
- > Min. installation height: 650 mm
- > Single fixing point on cabinet centre post
- > Shelves pull out independently
- > Set includes:
  - 2x Shelves, lava grey metal sides and base or laminated wooden shelves with a white base and polished chrome rail
  - 1x Pull-out and pivoting mechanism
  - Fitting instructions
- > Order qty: 1 set

Side Mounting

Handed  
L  
R

800

900

1000

Fixings included

## Cornerstone Maxx pull out unit with shelves, Planero lava grey



Right hand shown

For cabinet width	For door width	Left hand	Right hand
800 mm	400 mm	542.02.491	542.02.490
900 mm	450 mm	542.02.493	542.02.492
1000 mm	500 mm	542.02.495	542.02.494
1000 mm	600 mm	542.02.497	542.02.496

## Cornerstone Maxx pull out unit with shelves, white base with chrome rail



Right hand shown

For cabinet width	For door width	Left hand	Right hand
800 mm	400 mm	542.02.291	542.02.290
900 mm	450 mm	542.02.293	542.02.292
1000 mm	500 mm	542.02.295	542.02.294
1000 mm	600 mm	542.02.297	542.02.296

TCH DESIGN 2017. © Häfele U.K. Ltd 2017. Dimensional data not binding. We reserve the right to alter specifications without notice.