

CC92MX9

Cucina product

90cm Cooker with Double Oven and Gas Hob, Stainless Steel
Energy Efficiency Class AA

EAN13: 8017709176044

MAIN OVEN



- 7 Functions including Circulaire element with fan
- Oven capacity: gross- 79 litres, net 70 litres
- Digital Electronic Clock/Programmer
- Air cooling system
- Closed door grilling
- Easy clean enamel interior
- 5 cooking levels
- **Vapor clean programme**
 - Conventional: 0.85 kW/h
 - Forced air convection: 0.99 kW/h

AUXILIARY OVEN

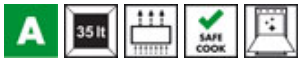

- 4 functions including upper & lower element
- Oven capacity: gross - 39 litres, net - 35 litres
- Variable grill
- Closed door grilling
- Air cooling system
- Easy clean enamel interior
- Forced air convection: 0.74 kW/h

HOB

- 5 gas burners
- Rear left: 1.80 kW
- Front left: Rapid 3.00 kW
- Centre: Ultra Rapid 3.50 kW
- Rear right: 1.75 kW
- Front right: 1.00 kW
- Automatic ignition



- **Safety Valves**

- Enamelled pan stands
- Adaptable for LPG
- Black feet and black plinth provided

Nominal Power: 4.30 kW

Power supply required: dedicated circuit fused at 30 Amp, or a 32 Amp circuit breaker

Standard Accessories

Main Oven:-
Extra deep tray
Chrome Shelf
Grill Mesh

Auxiliary Oven:-
Roasting/Grill Pan
Grill Mesh
Chrome Shelf

NB: This model replaces the CC92MX8

Functions



Options

- **KIT90X** - St/steel splash back
- **PRTX** - Pizza stone with handles
- **PALPZ** - Folding Pizza Shovel
- **TBX6090** - Teppanyaki grill plate
- **WOKGHU** - Wok Support

Smeg (UK) Limited
3 Milton Park, Abingdon
Oxon OX14 4RN
Tel. +44 (0)844 557 9907
Fax +44 (0)844 557 9337



Main Oven



Circulaire:

The combination of the fan and circular element around it gives a hot air cooking method. This provides many benefits including no preheat if cook time is more than 20 minutes, no flavour transfer when cooking different foods at the same time, less energy, and shorter cook times. Good for all types of food.



Upper and lower element only:

A traditional cooking method best suited for single items located in the centre of the oven. The top of the oven will always be hottest. Ideal for roast, fruit cakes, bread etc.



CIRCOGAS / FAN WITH LOWER ELEMENT:

In gas ovens the fan distributes the heat quickly and evenly throughout the oven cavity, avoiding flavour transfer when cooking a number of different dishes at the same time. In electric ovens this combination completes cooking more quickly of foods that are ready on the surface, but that require more cooking inside, without further browning.



Lower heating element only:

Ideal for foods that require extra base temperature without browning, e.g. pastry dishes, pizza. Also suitable for slow cooking of stews and casseroles.



Fan with grill element:

The fan reduces the fierce heat from the grill, providing an excellent method of grilling various foods, chops, steaks, sausages etc. giving even browning and heat distribution, without drying out the food. The top two levels recommended for use, and the lower part of the oven can be used to keep items warm at the same time, an excellent facility when cooking a grilled breakfast. Half grill (centre portion only) is ideal for small quantities of food.



Grill element:

For rapid cooking and browning of foods. Best results can be obtained by using the top shelf for small items, the lower shelves for larger ones, such as chops or sausages. For half grill heat is generated only at the centre of the element, so is ideal for smaller quantities.



Half grill:

For rapid cooking and browning of foods. Best results can be obtained by using the top shelf for small items, the lower shelves for larger ones, such as chops or sausages. For half grill heat is generated only at the centre of the element, so is ideal for smaller quantities.



Vapor clean
Vapor clean

Auxiliary Oven



Upper and lower element only:

A traditional cooking method best suited for single items located in the centre of the oven. The top of the oven will always be hottest. Ideal for roast, fruit cakes, bread etc.

**Lower heating element only:**

Ideal for foods that require extra base temperature without browning, e.g. pastry dishes, pizza. Also suitable for slow cooking of stews and casseroles.

**Grill element:**

For rapid cooking and browning of foods. Best results can be obtained by using the top shelf for small items, the lower shelves for larger ones, such as chops or sausages. For half grill heat is generated only at the centre of the element, so is ideal for smaller quantities.

**Half grill:**

For rapid cooking and browning of foods. Best results can be obtained by using the top shelf for small items, the lower shelves for larger ones, such as chops or sausages. For half grill heat is generated only at the centre of the element, so is ideal for smaller quantities.

Cucina Selection
90 cm
stainless steel
hob type: gas
energy rating AA

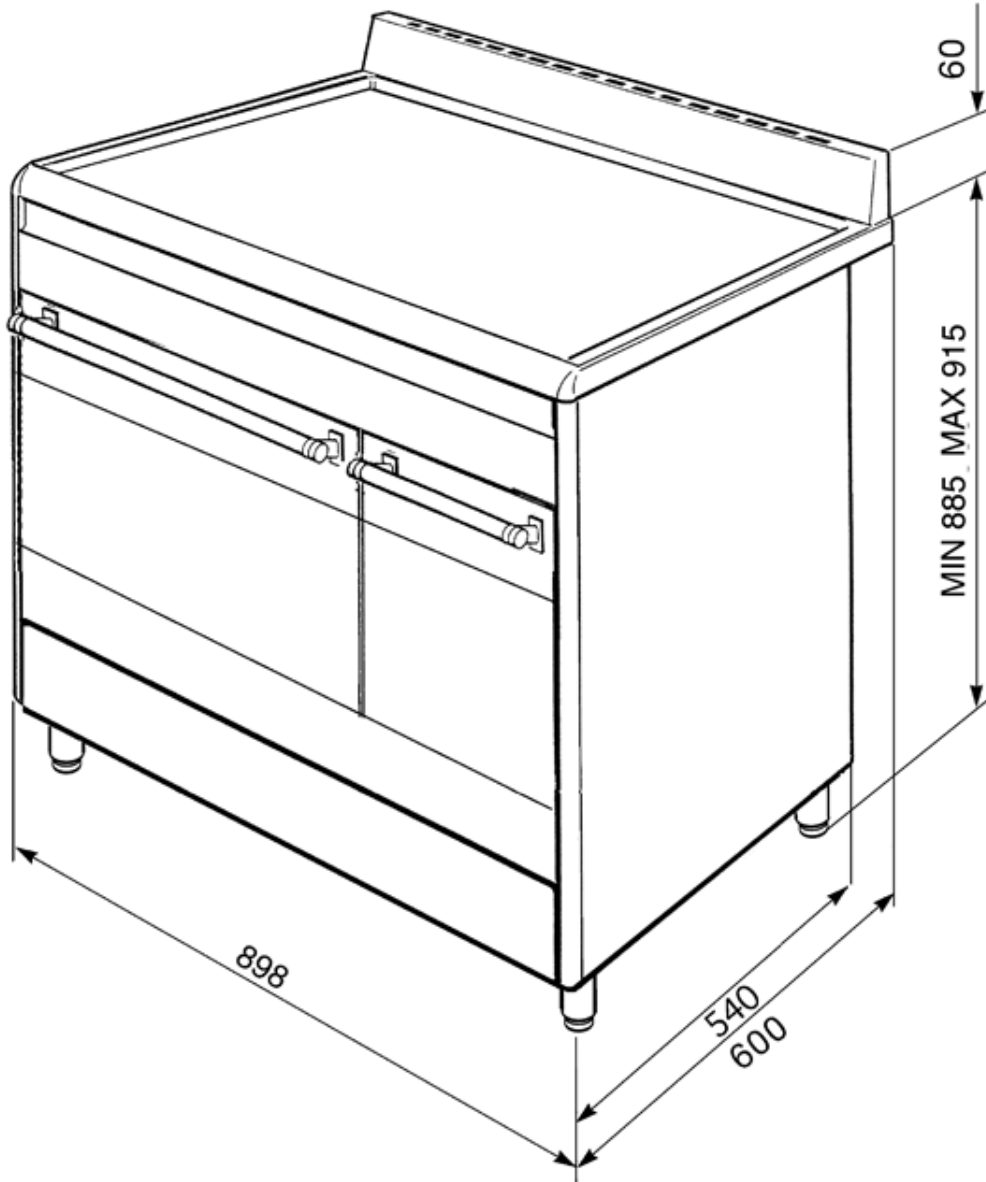

NB: Height with plinth installed is fixed at 900mm