

SI2M7643B New product

60cm Intuitive Slider Touch Control MultiZone Induction
Hob with Auto vent, Angled Edge Glass along the front

EAN13: 8017709254964

AVAILABILITY EXPECTED JUNE 2018

- 4 "full power" induction zones including:
- Front Left: Ø 210mm, 2.3kW – booster 3.2kW
- Rear Left Ø 210mm, 2.3kW – booster 3.2kW

The two zones on the left can be combined to create one Multizone: Ø 392/195mm

- Rear right: Ø 210mm, 2.3kW – booster 3.2kW
- Front right: Ø 210mm, 2.3kW – booster 3.2kW

The two zones on the right can be combined to create one Multizone: Ø 392/195mm

Auto vent

Intuitive Slider touch control

Multizone option

Eco-heat

Eco-off

- 4 independent boosters (P)

14 power levels, with quick setting

- Minute minder
- End of cooking timer & alarm
- Residual heat indicator
- Auto pan recognition and adjustment to pan size
- Automatic switch off when overheat or overflow
- Child safety lock
- Nominal power 7.20kW
- Supply can vary depending on usage, please consult a qualified electrician for ampere requirement

NB: only pans with a ferrous (magnetic) base are suitable for induction hobs.





Functions











 **Auto vent:**
Auto vent is a smart infrared system which connects the hood and the hob, automatically regulating the hood extraction speed depending on the temperature and power level selected on the hob.

 **Child lock:**
some models are fitted with a device to lock the programme/cycle so it cannot be accidentally changed.

  **Touch controls:**
Easy to use touch controls allow the appliance to be programmed at the touch of a button.

  **Power booster:**
option allows the zone to work at full power when very intense cooking is necessary.

  **Quick Start:**
When the Quick Start function is selected, the chosen temperature is reached faster. The heating element works at maximum power until the right temperature is reached.

  **Timer:**
All ceramic hobs have a timer which automatically ends cooking after a preset time.



SI2M7643B

induction
60 cm
touch control

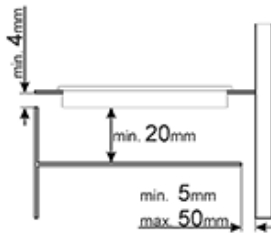
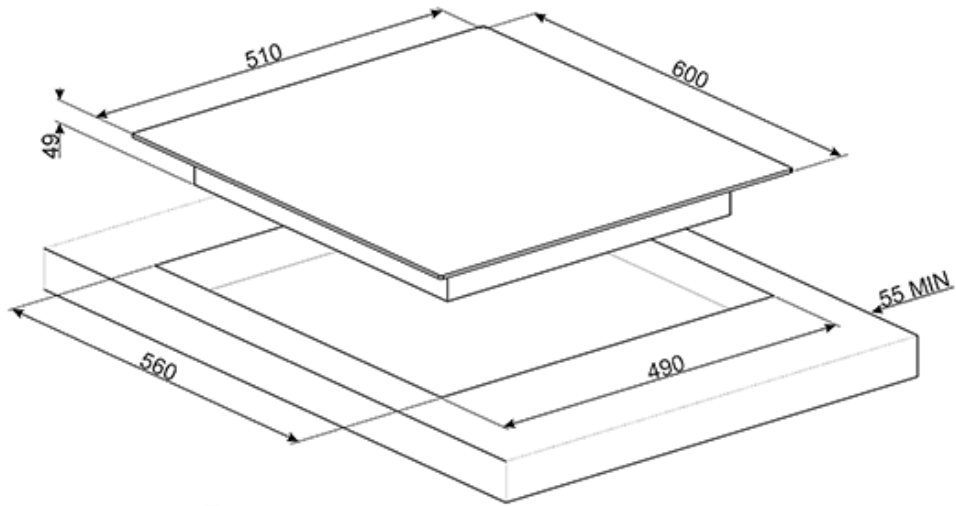

Smeg (UK) Ltd
The Magna Building, Wyndyke Furlong, Abingdon
OX14 1DZ
Tel. +44 (0)844 557 9907
Fax +44 (0)844 557 9337