

SFP6301TVX New product

classic

60cm "Classic" Pyrolytic Multifunction Oven, Finger-friendly Stainless steel and Eclipse Glass
Energy rating A+



- 10 functions + 1 cleaning function
- Compactscreen display
- Other functions: Defrost by time, Proving, Sabbath
- Other options: Keep warm, Eco light
- Quadruple glazed removable door
- Removable inner door glass
- Child safety lock
- Air cooling system
- Closed door grilling
- **Pyrolytic cleaning**
- Easy clean enamel interior
- Rapid pre-heating
- Metal side supports, 5 cooking levels
- 1 x Halogen light

Standard accessories:
Extra deep tray (40mm deep)
Partial telescopic guide set
Chrome shelf
Grill mesh

- Oven GROSS capacity: 79 litres
- Oven NET capacity: 70 litres
- Usable cavity space dimensions (HxWxD): 360x444x425mm

Nominal Power: 3.0 kW

13 Amp power supply required

Functions



Options

- **PRTX** - Pizza stone with handles
- **GT1T-2** - Pair of fully extractable telescopic guides
- **GT1P-2** - Pair of partially extractable telescopic guides
- **PALPZ** - Folding Pizza Shovel



Main oven

Upper and lower element only:

A traditional cooking method best suited for single items located in the centre of the oven. The top of the oven will always be hottest. Ideal for roast, fruit cakes, bread etc.

Fan with upper and lower elements:

The elements combined with the fan aim to provide more uniform heat, a similar method to conventional cooking, so pre-heat is required. Most suitable for items requiring slow cooking methods.

Circulaire:

The combination of the fan and circular element around it gives a hot air cooking method. This provides many benefits including no preheat if cook time is more than 20 minutes, no flavour transfer when cooking different foods at the same time, less energy, and shorter cook times. Good for all types of food.

Circulaire with upper and lower elements:

The use of the fan with both elements allows food to be cooked quickly and effectively, ideal for large joints that require thorough cooking. It offers a similar result to rotisserie, moving the heat around the food, instead of moving the food itself, enabling any size or shape to be cooked.

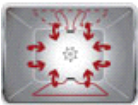
ECO:

The combination of the grill, fan (if present) and lower element is particularly suitable for cooking small quantities of food.

Grill element:

For rapid cooking and browning of foods. Best results can be obtained by using the top shelf for small items, the lower shelves for larger ones, such as chops or sausages. For half grill heat is generated only at the centre of the element, so is ideal for smaller quantities.

Fan with grill element:

The fan reduces the fierce heat from the grill, providing an excellent method of grilling various foods, chops, steaks, sausages etc. giving even browning and heat distribution, without drying out the food. The top two levels recommended for use, and the lower part of the oven can be used to keep items warm at the same time, an excellent facility when cooking a grilled breakfast. Half grill (centre portion only) is ideal for small quantities of food.

Lower heating element only:

Ideal for foods that require extra base temperature without browning, e.g. pastry dishes, pizza. Also suitable for slow cooking of stews and casseroles.



Circulaire with lower element :

The addition of the lower element adds extra heat at the base for food which requires extra cooking..

Pizza function:

The simultaneous operation of these three elements ensures an optimum cooking facility, ideal not only for pizza but also for cookies, quiches and flans.

Pyrolytic:

 Pyrolytic cleaning at 500°C destroys all the dirt deposits inside the oven. The process can be set from 1.5 hours to 3 hours, depending on the degree of dirt build up.

Smeg (UK) Ltd
The Magna Building, Wyndyke Furlong, Abingdon
OX14 1DZ
Tel. +44 (0)844 557 9907
Fax +44 (0)844 557 9337



SFP6301TVX

classic

single oven
60 cm
stainless steel
energy rating A+
electric pyrolytic

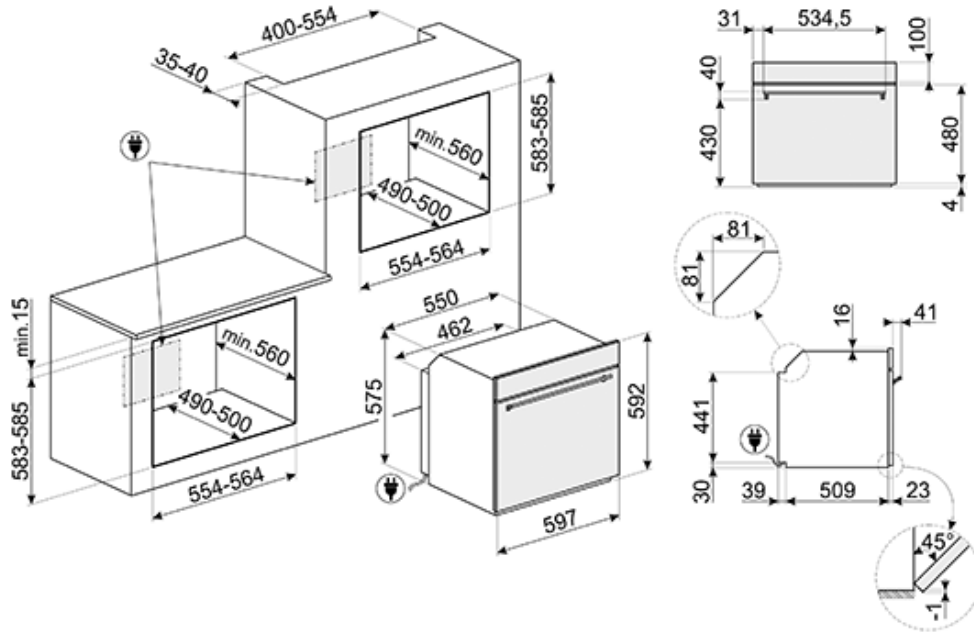

Smeg (UK) Ltd
The Magna Building, Wyndyke Furlong, Abingdon
OX14 1DZ
Tel. +44 (0)844 557 9907
Fax +44 (0)844 557 9337