

SFP6604WSPNR New product

Available soon

Dolce Stil Novo

60cm "Dolce Stil Novo" Smart Steam Pyrolytic Multifunction WIFI oven, Eclipse Black Glass with Copper Trim

Energy rating A+

For stockist information please contact Smeg UK directly
<http://www.smeguk.com/contact-us/>

EAN13: 8017709276096

Special promotion on this model* 5 year guarantee on parts and labour if purchased by 31st December 2020. Models included are all Dolce Stil Novo built in ovens & Combi appliances. Terms and conditions apply. Offer available from selected displaying retailers only. [For full terms and conditions please click here](#)

Please ensure that you have:

Minimum router capability of 2.4 GHz

IOS 10 or higher for iPhone users or Android 5.3 or Higher

This WIFI appliance will be unable to connect without either of these capabilities

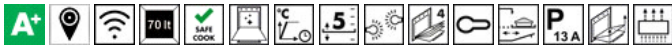

- 15 functions (including 5 steam) + 1 cleaning function
- **VIVOscreen display**
- **53 automatic programmes**
- **64 customisable recipes**
- **5 steam assisted cooking functions**
- **3 steam assisted levels (30ml, 100ml, 160ml)**
- Other functions: Defrost by time, defrost by weight, Plate rack/warmer, Proving, Sabbath
- Other options: SmartSense system, Keep warm, Eco light
- Quadruple glazed removable door
- Removable inner door glass
- Child safety lock
- Soft close door
- Air cooling system
- Closed door grilling
- **Pyrolytic cleaning**
- Easy clean enamel interior
- Rapid pre-heating
- Metal side supports, 5 cooking levels
- 2 x Halogen lights
- **Wi-fi connectivity via SmegConnect App**

STANDARD ACCESSORIES:

- 1 x extra deep tray (40mm deep)
- 1 x roasting/grill pan (20mm deep)
- 1 x set of telescopic guides – Total extraction
- 2 x chrome shelves
- 1 x Grill mesh
- 1 x Temperature probe**

- Oven GROSS capacity: 79 litres
- Oven NET capacity: 70 litres
- Usable cavity space dimensions (HxWxD): 360x460x425mm
- Nominal power: 3.0 kW
- 13 Amp power supply required

NB: Please be aware that products with a copper trim will naturally discolour overtime.



Functions



Options

- **GT1T-2** - Pair of fully extractable telescopic guides
- **PRTX** - Pizza stone with handles
- **PALPZ** - Folding Pizza Shovel
- **GT1P-2** - Pair of partially extractable telescopic guides

Versions

- **SFP6604WSPNR** - 60cm DSN Smart Steam Pyrolytic Multifunction WIFI oven, Eclipse Black Glass with Copper Trim
- **SFP6604WSPNX** - 60cm DSN Smart Steam Pyrolytic Multifunction WIFI oven, Eclipse Black Glass with Steel Trim



Main oven



Upper and lower element only:

A traditional cooking method best suited for single items located in the centre of the oven. The top of the oven will always be hottest. Ideal for roast, fruit cakes, bread etc.

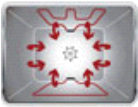

Fan with upper and lower elements:

The elements combined with the fan aim to provide more uniform heat, a similar method to conventional cooking, so pre-heat is required. Most suitable for items requiring slow cooking methods.



Circulaire:

The combination of the fan and circular element around it gives a hot air cooking method. This provides many benefits including no preheat if cook time is more than 20 minutes, no flavour transfer when cooking different foods at the same time, less energy, and shorter cook times. Good for all types of food.



Circulaire with upper and lower elements:

The use of the fan with both elements allows food to be cooked quickly and effectively, ideal for large joints that require thorough cooking. It offers a similar result to rotisserie, moving the heat around the food, instead of moving the food itself, enabling any size or shape to be cooked.

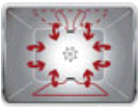

ECO:

The combination of the grill, fan (if present) and lower element is particularly suitable for cooking small quantities of food.



Grill element:

For rapid cooking and browning of foods. Best results can be obtained by using the top shelf for small items, the lower shelves for larger ones, such as chops or sausages. For half grill heat is generated only at the centre of the element, so is ideal for smaller quantities.



Fan with grill element:

The fan reduces the fierce heat from the grill, providing an excellent method of grilling various foods, chops, steaks, sausages etc. giving even browning and heat distribution, without drying out the food. The top two levels recommended for use, and the lower part of the oven can be used to keep items warm at the same time, an excellent facility when cooking a grilled breakfast. Half grill (centre portion only) is ideal for small quantities of food.



Lower heating element only:

Ideal for foods that require extra base temperature without browning, e.g. pastry dishes, pizza. Also suitable for slow cooking of stews and casseroles.



Pizza function:

The simultaneous operation of these three elements ensures an optimum cooking facility, ideal not only for pizza but also for cookies, quiches and flans.





Circulaire with lower element :

The addition of the lower element adds extra heat at the base for food which requires extra cooking..

Pyrolytic:

 Pyrolytic cleaning at 500°C destroys all the dirt deposits inside the oven. The process can be set from 1.5 hours to 3 hours, depending on the degree of dirt build up.

 **Circulaire with steam assist:**
Provides extra moisture to food during cooking. Excellent for bread baking. The moisture allows the bread dough to stretch further at the beginning of cooking, creating an aerated and light textured dough. The remaining part of the cooking process allows for the signature crust to form.

 **Circulaire + lower element with steam assist:**
Ideal for reheating flans and quiches. This function will re-crisp the base, whilst filling will not dry out due to the additional moisture in the cooking cavity.

 **Turbo with steam assist:**
Great for oven bakes such as potato gratins and savoury bakes. The steam allows the food to stay moist, but still maintain a crispy top.

 **Fan with grill with steam assist:**
For creating a perfectly roasted meat joint. The extra moisture keeps the meat juicy and tender, whilst the heat from the turbo function creates the caramelised flavours we know and love.

 **Fan assist with steam assist:**
Brilliant for the delicate cooking of foods like fish. Browning occurs at the same time as keeping the food moist.



SFP6604WSPNR

Dolce Stil Novo

single oven

60 cm

Eclipse Black Glass with Copper Trim
energy rating A+
electric pyrolytic steam assist

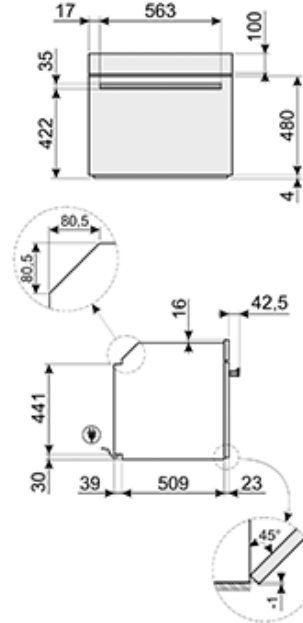
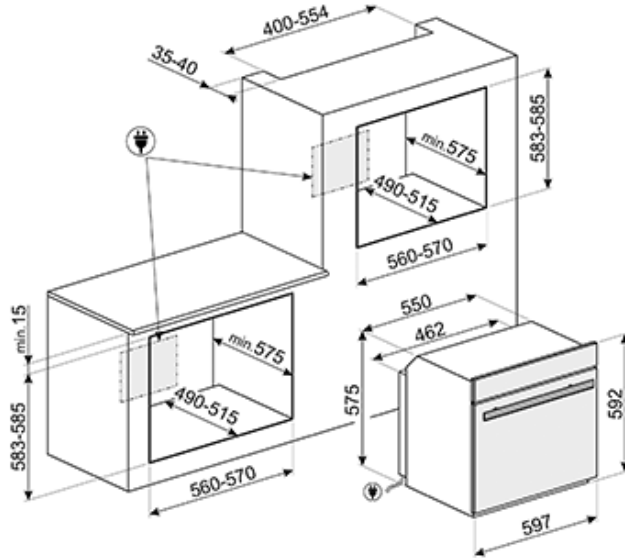

Smeg (UK) Ltd
The Magna Building, Wyndyke Furlong, Abingdon
OX14 1DZ
Tel. +44 (0)844 557 9907
Fax +44 (0)844 557 9337