

## UKC7172NP1 New product

Integrated In Column Combined Fridge & Freezer  
Energy Efficiency Class A+

EAN13: 8017709252380

- Gross capacity: 269 litres
- Sliding rail fitting
- Reversible door
- Noise level: 39 dB(A) re 1 pW
- Fire resistant back panel & new interior

### REFRIGERATOR

- Fresh Food capacity: 158 litres
- Automatic defrost
- 2 adjustable glass shelves
- 1 fruit & vegetable cover
- 2 fruit & vegetable drawers
- LED light

### FREEZER\*\*\*\*

- Frozen Food capacity: 88 litres
- Fast freezing button
- 4 drawers
- Ice box
- Completely FROST FREE
  
- Energy efficiency class: A+
- Energy consumption: 307 kWh/year
- Freezing capacity: 4 kg/24h
- Thaw time: 16 h
- Climatic class: SN-T

Rear panel material : Flame Retardant Aluminium Foil back



### Key to symbols





 **A+:**

Smeg products with A+ or A++ energy rating are highlighted with one of the following Symbols



**Automatic defrost:**

The automatic defrost system works by automatically defrosting the fridge section at regular intervals eradicating the need to defrost altogether.



# UKC7172NP1

fridge freezer  
built-in  
built-in  
54 cm  
energy rating A+

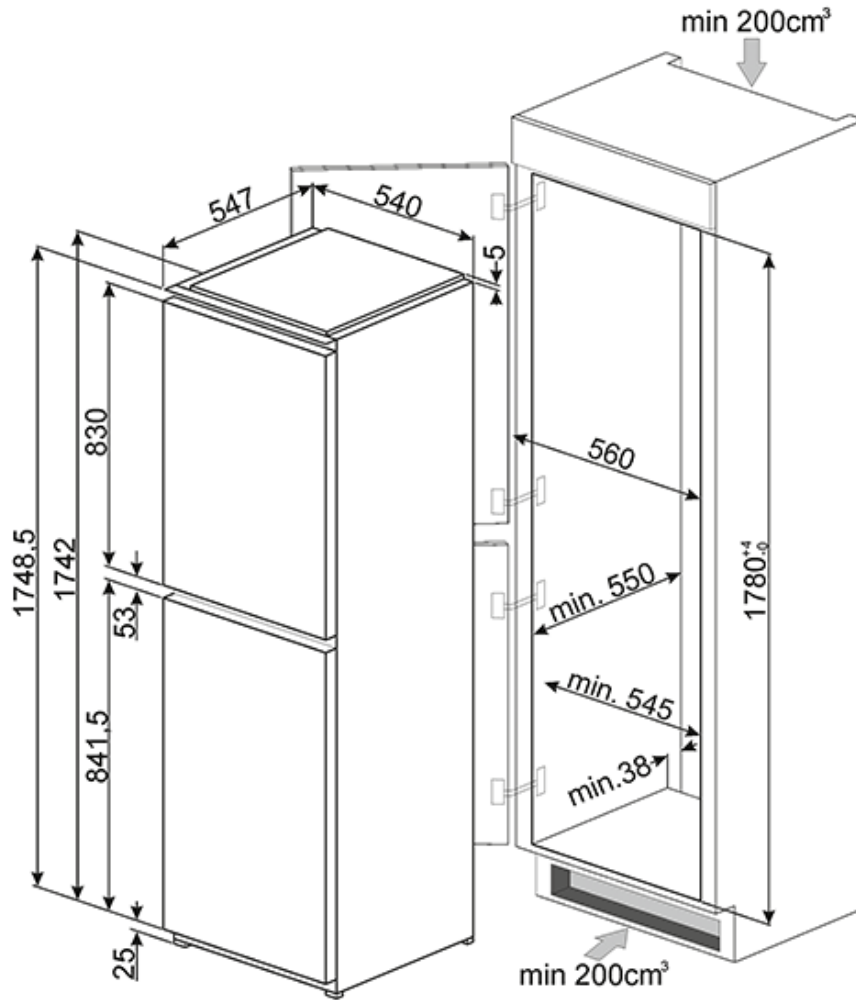

Smeg (UK) Ltd  
The Magna Building, Wyndyke Furlong, Abingdon  
OX14 1DZ  
Tel. +44 (0)844 557 9907  
Fax +44 (0)844 557 9337